

010 DRAWING SHOWS LOCATION OF FREIGHTLINER TL3 CHASSIS COMPONENTS WITH PASSENGER SIDE FUEL TANK



LOCATION OF REMOTE ENGINE CONN.



LOCATION OF EXHAUST



LOCATION OF AIR DRYER (IF REQD)

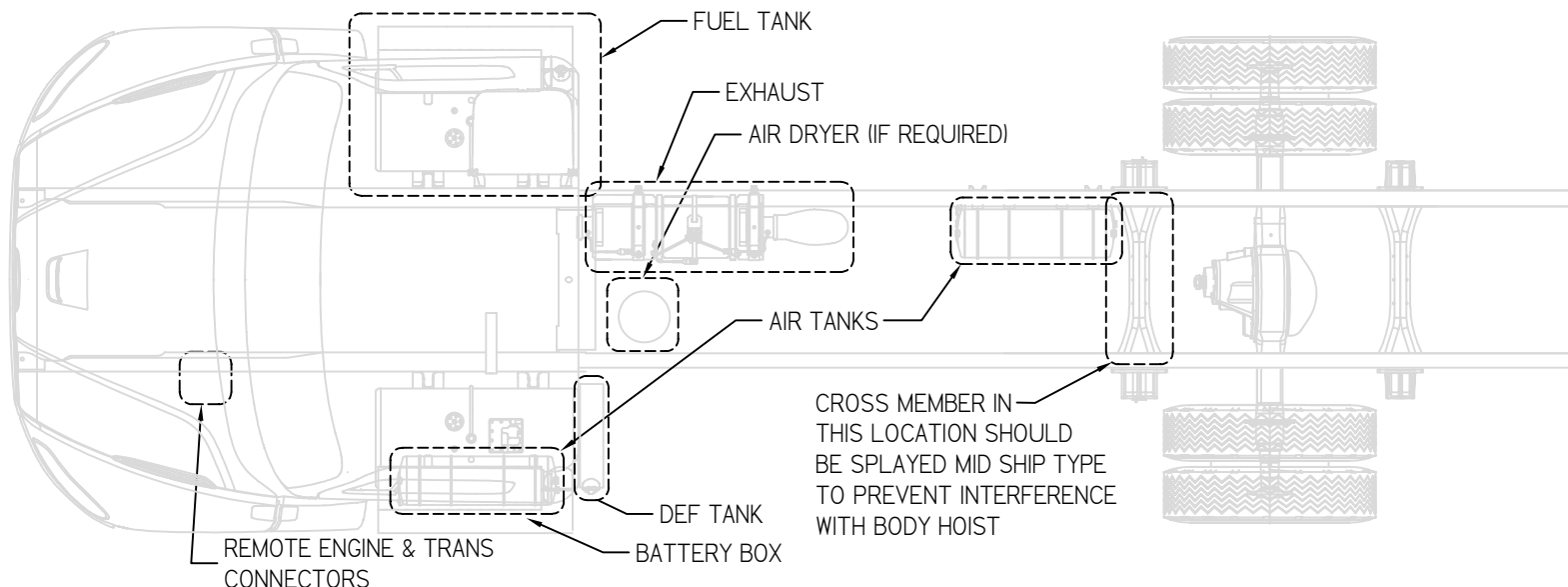

FREIGHTLINER FEATURE CODES

FUEL TANK = 206-192* OR 206-195* OR 206-034* AND 212-007* RH
 DEF TANK = 23U-001 LH
 EXHAUST = 016-101
 VEHICLE INT WIRING = 353-023*
 TRAILER CONNECTOR (if required) = 297-001
 AIR TANKS = 460-057*
 AIR DRYER (IF REQUIRED) = 479-003
 BATTERY BOX = 290-017* & 282-001 LH*
 BATTERY SWITCH = 293-058*
 REMOTE ENG CONN. = *148-073, *163-004, *87L-003
 REMOTE TRANS CONN. = 34C-001*
 GRAB HANDLES = 678-001*
 NO REAR SHOCK ABSORBERS = 439-998*
 PTO SWITCH = 372-035*
 CUSTOMER INSTALLED CHELSEA PTO = 362-035*
 BOOM UP ALARM = 33A-804*
 FOUR SWITCHES IN DASH WIRED TO BOC = 329-012*
 * INDICATES A REQUIRED FEATURE

(USE THESE FOR A CHASSIS THAT REQUIRES 5 OR MORE ACCESSORY SWITCHES OR HIGH AMP OUTPUTS OR IF ANY OF THE SWITCHES REQUIRE LOGIC CONTROLLED OUTPUT

NOTE THAT 33A-804, 329-010, 329-012 CAN NOT BE USED WITH ANY OF THE BELOW FEATURES.
 SMARTPLEX HUB MODULE - 35M-001
 SMARTPLEX BOOM UP ALARM = 44V-001
 SMARTPLEX BOOM UP & OUTRIGGER DEPLOYED LIGHTS AND ALARMS = 44V-002
 SMARTPLEX LATCHING SWITCHES = 44R-XXX
 NOTE: THE LAST 3 DIGITS OF THE SWITCH CODE ARE THE NUMBER OF SWITCHES DESIRED.

TL3 MINIMUM CHASSIS REQUIREMENTS

BODY STYLE = CONVENTIONAL CAB
 CAB TO AXLE/TRUNION DIMENSION = 168" for 18' body, 186" for 20' body, or 192" for 22' body
 AFTER FRAME= 80" for 18' & 20' BODY
 96" for 22' BODY
 FRONT AXLE RATING = 12,000 LBS.
 REAR AXLE RATING = 21,000 LBS.
 GVW RATING = 33,000 LBS.
 FRAME = 1,800,000 RBM
 FRAME THICKNESS = 11/32" MINIMUM
 ENGINE = 240 HP DIESEL
 TRANSMISSION = ALLISON 3500 RDS WITH PTO PROVISION WITH I68.
 *NO TRANS MOUNTED COOLER OR RETARDER - THESE OPTIONS WILL PROMPT A PTO UPCHARGE.

DEVIATIONS FROM THIS LAYOUT COULD RESULT IN ADDITIONAL CHARGES AND/OR DELAYS IN PRODUCTION.

		PETERSEN INDUSTRIES INC. 4000 S.R. 60 WEST LAKE WALES, FL. 33859-8234 TEL: (863) 676-1493 FAX: (863) 676-6844	
TITLE: FREIGHTLINER TL3 CHASSIS RH FUEL TANK			
PART NUMBER: 00 08 04 002 0			SCALE: NA
DRAWN BY: JAC	APPROVED BY:	DATE: 12/18/19	SHEET: 1 OF 1

010 DRAWING SHOWS LOCATION OF FREIGHTLINER TL3 CHASSIS COMPONENTS WITH DRIVER SIDE FUEL TANK



LOCATION OF REMOTE ENGINE CONN.



LOCATION OF EXHAUST



LOCATION OF AIR DRYER (IF REQD.)

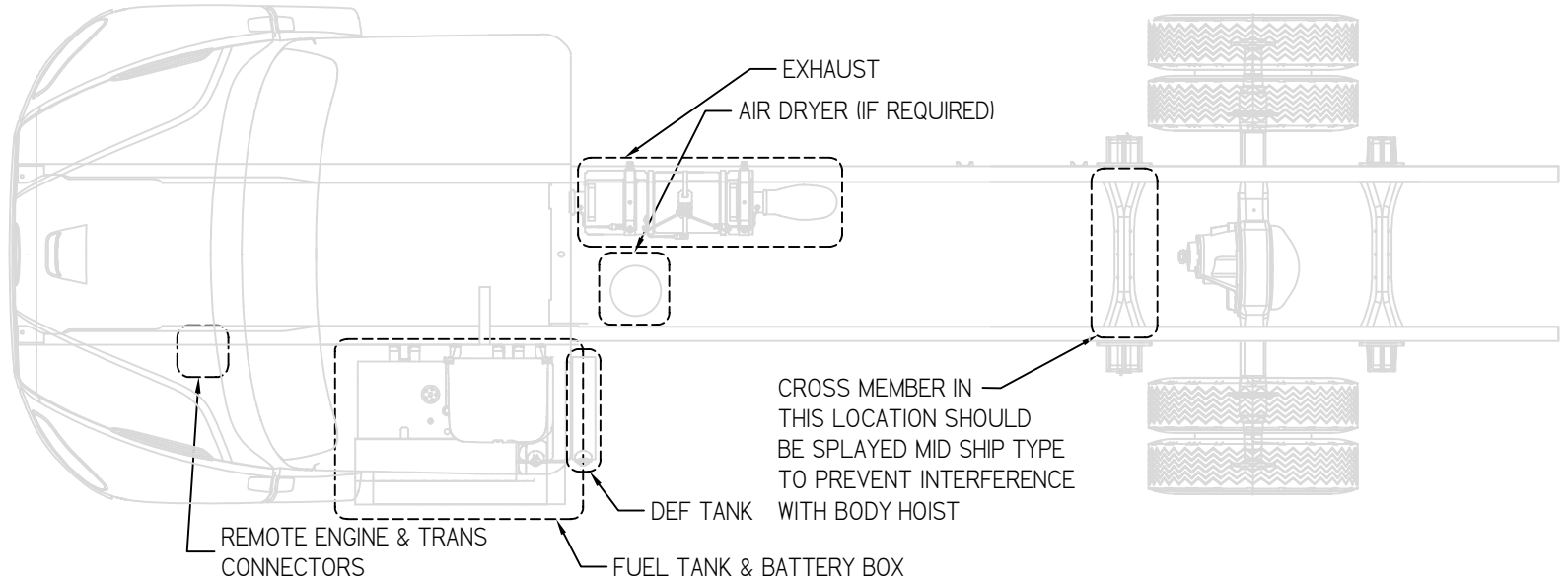

FREIGHTLINER FEATURE CODES

FUEL TANK = 204-192* OR 204-195* OR 204-034*
 DEF TANK = 23U-001 LH
 EXHAUST = 016-101
 VEHICLE INT WIRING = 353-023*
 TRAILER CONNECTOR (if required) = 297-001
 AIR TANKS = 460-057*
 AIR DRYER (IF REQUIRED) = 479-003
 BATTERY BOX = 290-017* & 282-001 LH*
 BATTERY SWITCH = 293-058*
 REMOTE ENG CONN. = *148-073, *163-004, *87L-003
 REMOTE TRANS CONN. = 34C-001*
 GRAB HANDLES = 678-001*
 NO REAR SHOCK ABSORBERS = 439-998*
 PTO SWITCH = 372-035*
 CUSTOMER INSTALLED CHELSEA PTO = 362-035*
 BOOM UP ALARM = 33A-804*
 FOUR SWITCHES IN DASH WIRED TO B0C = 329-012*
 * INDICATES A REQUIRED FEATURE

(USE THESE FOR A CHASSIS THAT REQUIRES 5 or MORE ACCESSORY SWITCHES OR HIGH AMP OUTPUTS OR IF ANY OF THE SWITCHES REQUIRE LOGIC CONTROLLED OUTPUT

NOTE THAT 33A-804, 329-010, 329-012 CAN NOT BE USED WITH ANY OF THE BELOW FEATURES.
 SMARTPLEX HUB MODULE - 35M-001
 SMARTPLEX BOOM UP ALARM = 44V-001
 SMARTPLEX BOOM UP & OUTRIGGER DEPLOYED LIGHTS AND ALARMS = 44V-002
 SMARTPLEX LATCHING SWITCHES = 44R-XXX
 NOTE: THE LAST 3 DIGITS OF THE SWITCH CODE ARE THE NUMBER OF SWITCHES DESIRED.

TL3 MINIMUM CHASSIS REQUIREMENTS

BODY STYLE = CONVENTIONAL CAB
 CAB TO AXLE/TRUNION DIMENSION = 168" for 18' body, 186" for 20' body, or 192" for 22' body
 AFTER FRAME= 80" for 18' & 20' BODY
 96" for 22' BODY
 FRONT AXLE RATING = 12,000 LBS.
 REAR AXLE RATING = 21,000 LBS.
 GVW RATING = 33,000 LBS.
 FRAME = 1,800,000 RBM
 FRAME THICKNESS = 11/32" MINIMUM
 ENGINE = 240 HP DIESEL
 TRANSMISSION = ALLISON 3500 RDS WITH PTO PROVISION WITH 168.
 *NO TRANS MOUNTED COOLER OR RETARDER - THESE OPTIONS WILL PROMPT A PTO UPCHARGE.

DEVIATIONS FROM THIS LAYOUT COULD RESULT IN ADDITIONAL CHARGES AND/OR DELAYS IN PRODUCTION .



PETERSEN INDUSTRIES INC.
 4000 S.R. 60 WEST
 LAKE WALES, FL. 33859-8234
 TEL: (863) 676-1493 FAX: (863) 676-6844

TITLE: FREIGHTLINER TL3 CHASSIS LH FUEL TANK			
PART NUMBER: 00 08 04 002 0			SCALE: NA
DRAWN BY: JAC	APPROVED BY:	DATE: 12/18/19	SHEET: 1 OF 1