

Specifications & Technical Data*

07/11

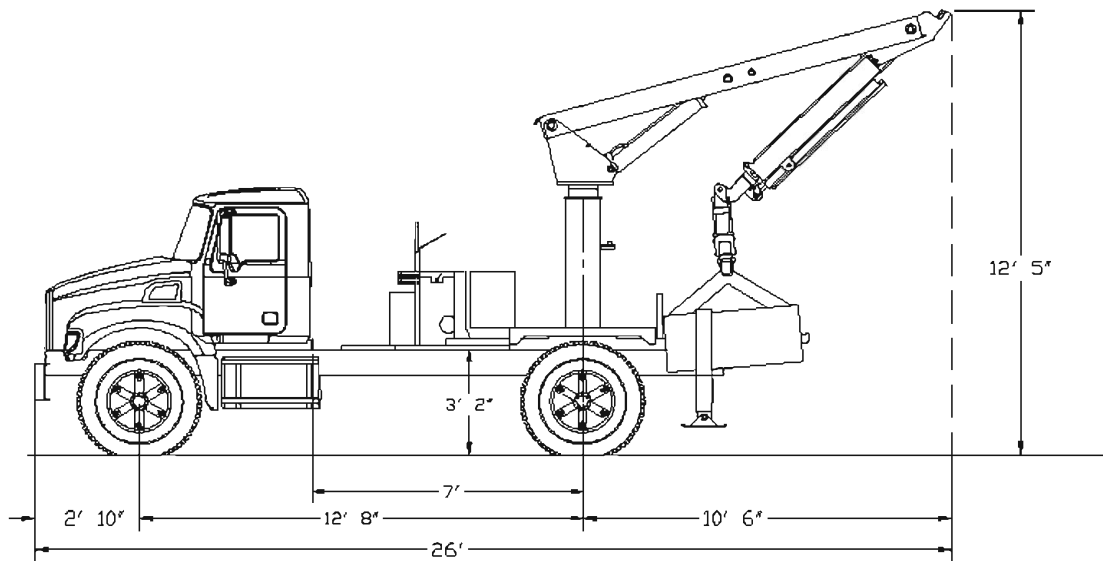

System Description

The Model RL-3 Lightning Loader®, a grapple loader mounted on a short frame chassis, was specifically configured to achieve greater maneuverability. Intended use is for loading into attached dump trailers or into separate haul trucks.

Control Options

Dual manual controls for outriggers and loader on both sides of the truck for accessibility and visibility come standard on this model. QUADSTICK® mechanically linked dual joystick controls are also an available option on the RL-3. Side-mount seat controls or an all-weather cab are also available options on the RL-3.

Lift Capacities

Radius	Over Rear	Over Side
10 ft radius	7,100 lbs	5,500 lbs
16 ft radius	4,400 lbs	3,100 lbs
20 ft radius	3,200 lbs	1,800 lbs

Note: Weight of attachment not subtracted from above listed lifting capacities. Trash bucket weighs 1,000 lbs. Capacities shown do not exceed 85% vehicle tipping moment (outriggers engaged, loader on firm, level ground).

General Specifications

Reach	20 ft
Main Boom & Tip Boom	16 ft
Tip Extension	4 ft
Tare Weight (empty)	18,240 lbs
Outrigger Span	11 ft 8 in

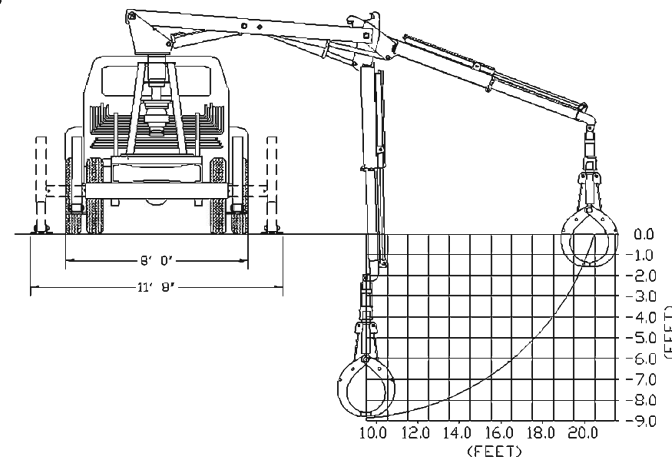

Recommended Chassis (minimum)

Body Style	Conventional Cab
Cab-to-Axle Dimension	84"
Front Axle Rating	9,000 lbs
Rear Axle Rating	21,000 lbs
GVW Rating	30,000 lbs
Frame	900,000 RBM
Engine	210 HP Diesel
Transmission	Automatic

*Petersen Industries, Inc. reserves the right to change product design and specifications at any time without notice. There may be more specifications than listed herein. Consult your Petersen dealer for complete specifications.

1-800-930-LOAD (5623)
www.petersenind.com



4000 SR 60 West
Lake Wales, FL 33859